

REMARK

1. Glass Thk: 0.7mm
2. Film Type: Non-Glare
3. Total Thk: 0.95±0.15mm
4. Linearity: ±1.8% or less
5. Transmittance: 80% or more
6. Resistance
 $100 < X < 1200 \text{ ohm}$
 $100 < Y < 1200 \text{ ohm}$
7. Connector: FPC
8. General Tolerance: ±0.3mm

CIRCUIT DIAGRAM

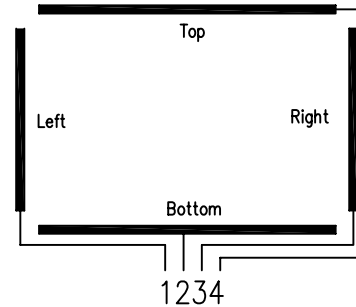

SIGNAL ASSIGNMENT

Pin No	Signal
1	LEFT
2	BOTTOM
3	RIGHT
4	TOP

Detail "AA" (Scale=3/1)

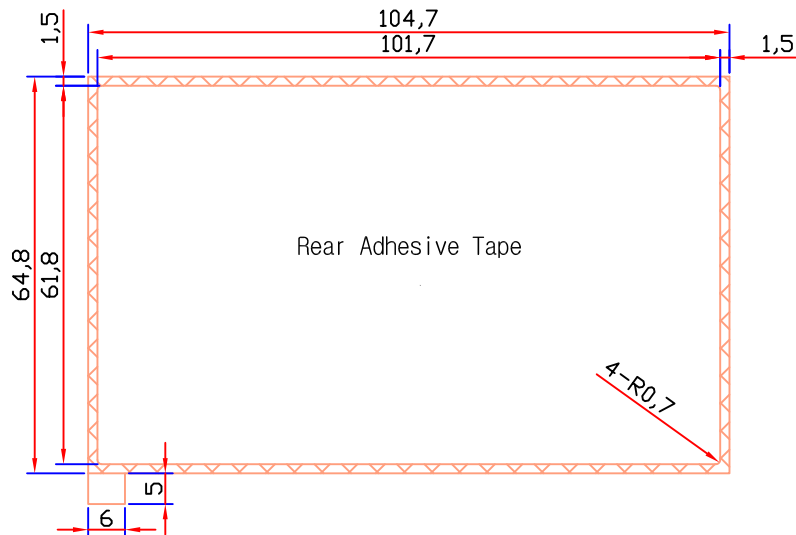
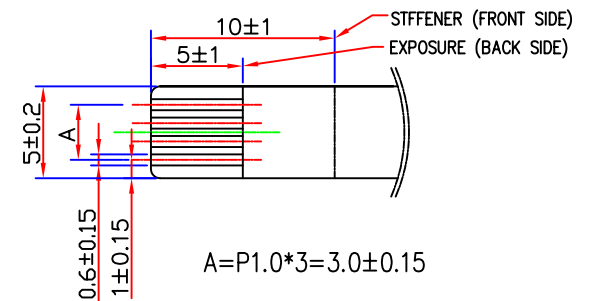

Web-Site @ www.hantouchusa.com

NOTE: The HantouchUSA Incoming Inspection Standard is part of this drawing. This quality and performance document can be viewed at: www.hantouchUSA.com, under Incoming Inspection Standards.

APPROVE		UNIT	mm	PROJECTION	DRAWING NO.	REV.
CHECK		SCALE	NONE		H8043A-NCOFB54-R	
DESIGN		 Touch Screen Specialists			DESCRIPTION	SHEET
DRAW					4.3 TOUCH PANEL	1/1

0	NEW DRAW	06.07.24	H. Y. IM	K. B. KIM	T. S. KANG
REV.No.	REVISED	DATE	DRAWN	CHECKED	APPROVED